

SPECIFICATION SHEET



Industrial Conductivity (Electric Conductivity) Detector

A5/A6 type (For general multipurpose)
AR4/AR5 type (for small purified water equipment)

Dual electrode conductivity (electrical conductivity) detector with large measurement range from the ultrapure water of semiconductor and power generating equipment to the river water and plant drainage.

The installation methods include insertion, drop-in and immersion type and flow through type.

Please refer to the electro-magnetic induction type for high electric conductivity (5000 μ S/cm above) agents such as acid and alkali and sea water.

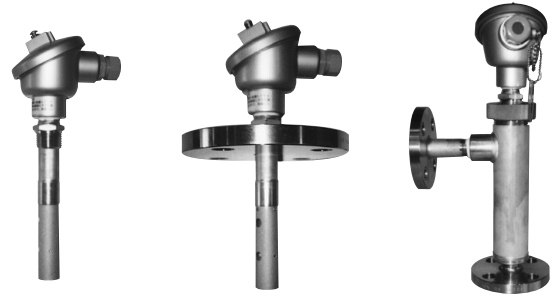

A6 type screw-in type

A6 type flange type

A6 type with SUS case

Features

- There are 4 types of cell constants: 0.01/cm, 0.1/cm, 1/cm and 10/cm. The ultrapure water of less than 0.2 μ S/cm to the drainage of 10000 μ S/cm can be tested accurately. (A5/A6 type)
- The sealing glass and PTFE are used as the insulating and sealing materials of internal and external poles, so the product has high heat resistance and pressure resistance. (A5/A6 type)
- The connector box is integrated type, so the wires and detector connected with the converter can be easily disassembled.
- The small portable type AR4/AR5 is not limited in terms of installation method.



A6 type with PP case

AR4 type screw-in type

AR5 type screw-in type

Basic specifications

Model	A5 type	A6 type	AR4 type	AR5 type
Application • features	Drop-in type	General universal type	For small purified water equipment	
Cable connection method	Waterproof direct connection type	Connector box type	Connector type	Connector box type
Installation method	Attached stainless steel lock	screw-in, flange, flow-through type	R3/4 screw-in, flow liquid type	
Materials of liquid receiving part	SUS316 sealing glass PTFE		Titanium PPS FKM	
Cell constant	0.01/cm, or 0.1/cm, or 1/cm, or 10/cm		0.01/cm, or 0.1/cm	
Sample water temperature	0 to 55°C*	0 to 100 (80) °C**	0 to 100°C*	
Sample water pressure	0.1MPa below	2.0 (1.0) (0.3) MPa below	0.5MPa below	
Temperature compensation factor	Thermistor (5k Ω at25°C)			
Structure	Outdoor installation, rain proof		Indoor installation	

*No freezing

Structure diagram

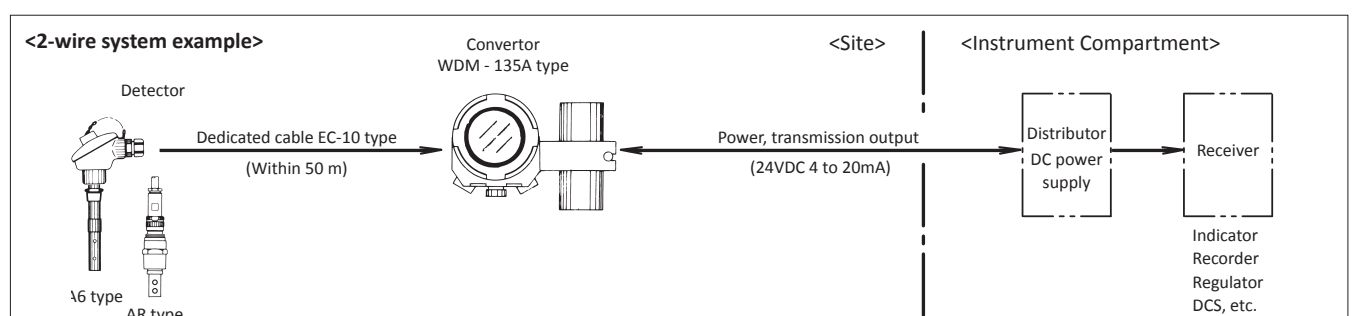

Cell constant and Measurement range (S/m is in unit of SI)

Sample water classification	Ultrapure water	Purified water	Boiler water	Rain water (underground water)	Tap water	River water	Industrial drainage (note)
Cell constant	0.01/cm (1.0/m)			0.1/cm (10/m)	1/cm (100/m)	10/cm (1000/m)	
Measurement range	0 to 0.2 (20)	0 to 1.0 (100)	0 to 20 (2)	0 to 200 (20)	0 to 2 (200)	0 to 5 (500)	
	0 to 0.5 (50)	0 to 2.0 (200)	0 to 50 (5)	0 to 500 (50)	0 to 5 (500)	0 to 10 (1000)	
		0 to 5.0 (500)	0 to 100 (10)	0 to 1000 (100)			
		0 to 10 (1000)					
Unit	$\mu\text{S/cm}$ ($\mu\text{S/m}$)	$\mu\text{S/cm}$ ($\mu\text{S/m}$)	$\mu\text{S/cm}$ (mS/m)	$\mu\text{S/cm}$ (mS/m)	$\mu\text{S/cm}$ (mS/m)	mS/cm (mS/m)	

(Note): Although the cell constant 10/cm is used in the test of 2mS/cm (200mS/m) above, it is recommended to use high-performance and user-friendly electro-magnetic induction conductivity detector.

A type detector

Model of general A type electrode

- A □ - □ □ □
- 5 Cable direct connection (only limited to drop-in type)
- 6 Connector box changeover
- General 1
- 1 (Temperature compensation: The structure used shall be compatible with ordinary water and ultrapure water)
- Progress conflict
- 1 Pipe insertion or immersion type screwed connection
- 2 Pipe insertion or immersion type flange connection
- 3 Flow-through type screwed connection with SUS316 case
- 4 Flow-through type flange connection with SUS 316 case
- 5 Flow-through type screwed connection with PP case
- 6 Flow-through type flange connection with PP case
- 7 Drop-in type or immersion type (no connection part)
- Cell constant (design value)
- 1 0.01/cm (1/m)
- 2 0.1/cm (10/m)
- 3 1/cm (100/m)
- 4 10/cm (1000/m)

Schematic diagram of structure

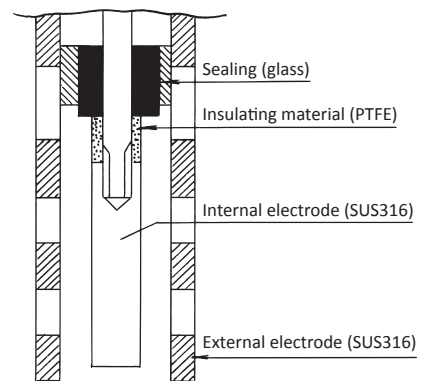

Dimensions

Unit : mm

● Screw-in type A6-11□ type

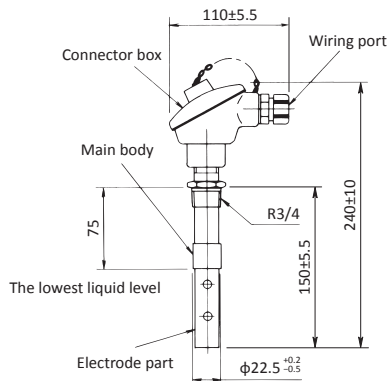

Cell constants: 0.01, 0.1, 1.0/cm

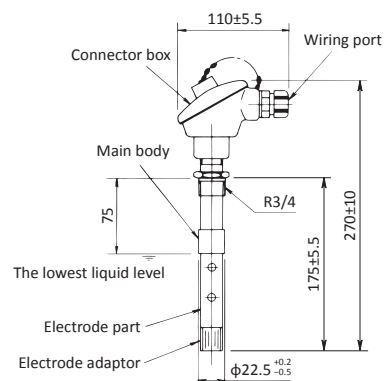

Cell constant: 10 /cm

● Flange type A6-12□ type

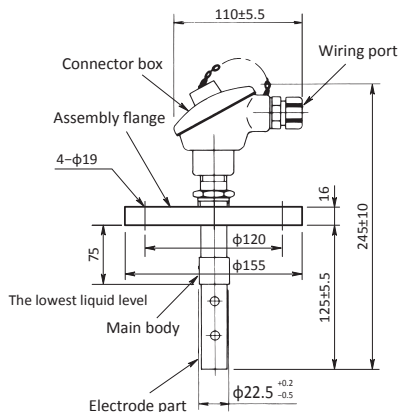

Cell constants: 0.01, 0.1, 1.0 /cm

● Immersion type A6 - 17□ type

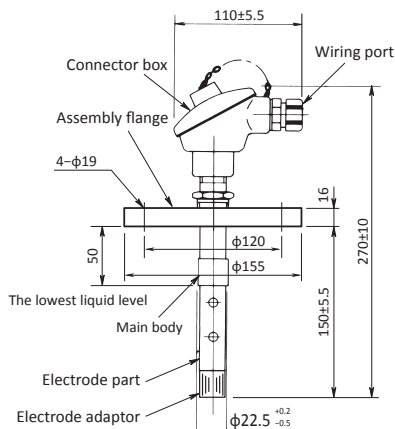

Cell constant: 10 /cm

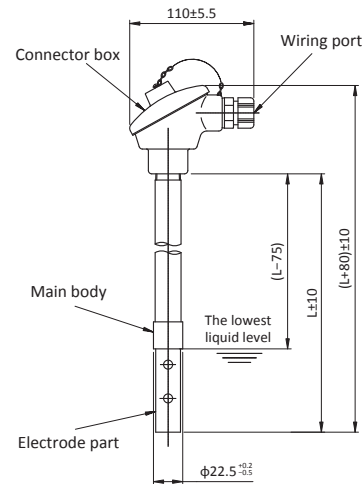

● Flow-through type with a SUS case (screwed connection) A6 - 13□ type

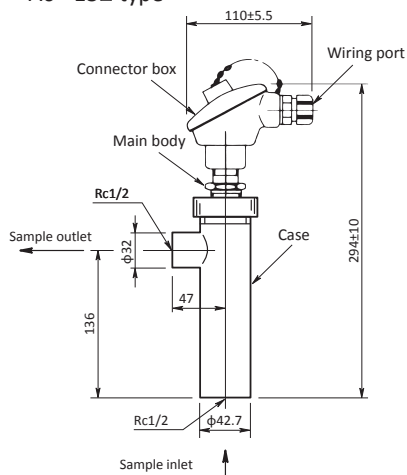

Screw specification: Rc 1/2

● Flow-through type with a SUS case (flange connection) A6-14□ type

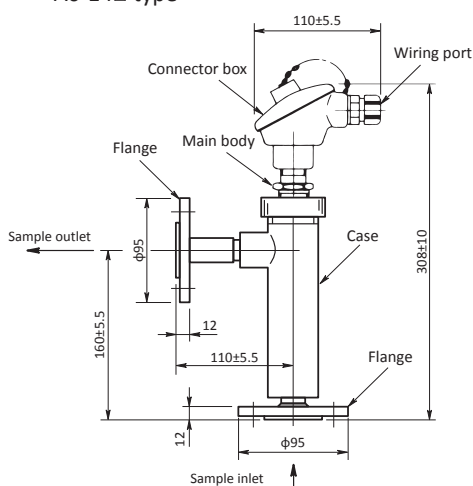

Flange specification: 15A JIS 10K RF

● Drop-in type A6 - 17□ type

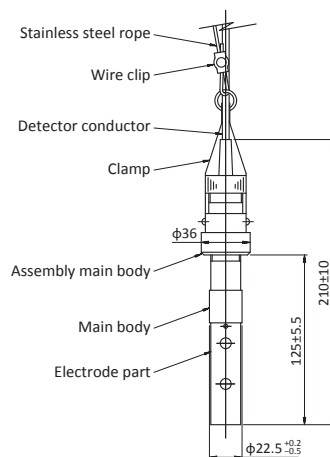

Standard specification

Product name	: Industrial conductivity detector	Flow rate or flow....	: 0.01 to 5m/s (When a case is equipped, flow is 0.5 to 10L/min)
Model	: A (for general use)	Temperature	: Thermistor
Test objects	: Electrical conductivity of ultrapure water, purified water, industrial water and drainage	sensing element	: Thermistor
Cell constant	: 0.01/cm, 0.1/cm, 1.0/cm, 10/cm	Material	: Main body.....SUS316 Connector box...aluminum casting Electrode.....SUS316 Insulating material of electrode... glass (sealing) PTFE
Ambient temperature,	: -10 to 60°C, 95%RH below humidity	Shell.....	: SUS316 or PP
Sample water conditions	: No freezing	Cable connection method	: Connector box, etc.
Temperature range...	: 0 to 80°C (PP case) 0 to 100°C (in case of overall manufacturing of SUS316)	Weight	: Screw in type R3/4 about 0.5kg
Pressure range.....	: 2.0MPa below (The upper limit of flange connection type is the nominal pressure value of flange. The pressure of PP case is 0.3MPa below)	Powder spray color	: Connector box.....metallic silver
		Structure	: Rain-proof type

Product code

● Screw-in type type A6-11□ type

A61D-3-□□□□□□□□□□	Model	Main material of electrode
A	SUS316: standard
B	SUS316L (including screw part)
1	Connecting screw specification*1
2	R3/4: Standard
3	R1
4	NPT3/4
	M42 cap nut (for a flow-through type with a case)
	L size below screw:*1
0	0.01/0.1/1 10 ← Cell constant
2	150mm 175mm : standard
3	525mm 550mm
4	1,025mm 1,050mm
5	1,525mm 1,550mm
	2,025mm 2,050mm
Y	General Y
Y	General Y
Y	General Y
Y	General Y
1	Cell constant
2	A6-111 0.01/cm
3	A6-112 0.1/cm
4	A6-113 1/cm
5	A6-114 10/cm
5	Cell constant (SI unit system)
6	A6-111 1/m
7	A6-112 10/m
8	A6-113 100/m
8	A6-114 1000/m
0	Wiring interface adaptor integration
1	No G1/2: standard
2	G3/4 SUS304
3	NPT1/2 SUS304
3	NPT3/4 SUS304
0	Oil-prohibiting treatment*2
1	No
1	Yes
A	Mark form
B	Japanese
B	Designated English
0	Combined convertor*3
0	Manufacturing simultaneously
1	No

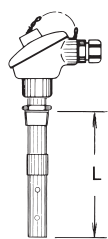

Custom spec. code;
Numeric digit: 9
Alphabet: Z

● Flange insertion type A6-12□ type

A61D-3-□□□□□□□□□□	Model	Main material of electrode
A	SUS316: standard
B	SUS316L (including flange part)
Y	General Y
Y	General Y
Y	General Y
Y	General Y
A	Flange connection specification
B	50A JIS 10K FF: Standard
C	50A JIS 5K FF: WS-21 detection part interchange
	2"ANSI 150LB RF
	Size below flange*1
0	0.01/0.1/1 10 ← Cell constant
1	125mm 150mm : standard
2	150mm 175mm
3	500mm 525mm
4	1,000mm 1,025mm
5	1,500mm 1,525mm
	2,000mm 2,025mm
Y	General Y
Y	General Y
Y	General Y
1	Cell constant
2	A6-121 0.01/cm
3	A6-122 0.1/cm
4	A6-123 1/cm
5	A6-124 10/cm
5	Cell constant (SI unit system)
6	A6-121 1/m
7	A6-122 10/m
8	A6-123 100/m
8	A6-124 1000/m
0	Wiring interface adaptor integration
1	No G1/2: standard
2	G3/4 SUS304
3	NPT1/2 SUS304
3	NPT3/4 SUS304
0	Oil-prohibiting treatment*2
1	No
1	Yes
A	Mark form
B	Japanese
B	Designated English
0	Combined convertor*3
0	Manufacturing simultaneously
1	No

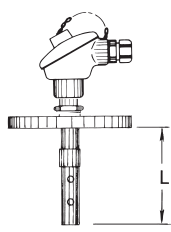

Custom spec. code;
Numeric digit: 9
Alphabet: Z

*1. If L size below the screw exceeds 1025 (1050) mm and the extended part is thickened, the screw size is R1 (cannot be R3/4)

In addition, if the L size is 525 mm above and sample water flow rate exceeds 0.1m/s (standard), the protective tube for reinforcing the detector needs to be used.

*2. Oil-prohibiting treatment means cleaning the electrode part in contact with the liquid with ethyl alcohol.

*3. If not manufacturing simultaneously with the convertor, please notify the model and production No. of combined convertor.

Notes

- A6 electrode is connector box type, so please order the dedicated cable EC-10 type (outer diameter: φ8).
- Temperature range of sample water is 0 to 100°C, and the maximum pressure is 2.0MPa.
- For the high conductivity test range with the cell constant of 10/cm (1000/m), the electromagnetic induction type is recommended.

*1. If the L size is 500 mm above and sample water flow rate exceeds 0.1m/s (standard), the protective tube for reinforcing the detector needs to be used.

*2. Oil-prohibiting treatment means cleaning the electrode part in contact with the liquid with ethyl alcohol.

*3. If not manufacturing simultaneously with the convertor, please notify the model and production No. of combined convertor.

Notes

- A6 electrode is connector box type, so please order the dedicated cable EC-10 type (outer diameter: φ8).
- Temperature range of sample water is 0 to 100°C, and the nominal pressure value of maximum pressure flange is 1.0MPa.
- For the high conductivity test range with the cell constant of 10/cm (1000/m), the electromagnetic induction type is recommended.

● Immersion type A6-17□ type

A61D-3-□□□□□□□□□□ Model		Main material of electrode	
A	SUS316: standard	
B	SUS316L	
Y	General Y	
Y	General Y	
Y	General Y	
Y	General Y	
Y	General Y	
Y	General Y	
		Immersion length L size *1	
		0.01/0.1/1	10← Cell constant
2	500mm	525mm
3	1,000mm	1,025mm
4	1,500mm	1,525mm
5	2,000mm	2,025mm
		Cell constant	
1 A6-171	0.01/cm	
2 A6-172	0.1/cm	
3 A6-173	1/cm	
4 A6-174	10/cm	
		Cell constant (SI unit system)	
5 A6-171	1/m	
6 A6-172	10/m	
7 A6-173	100/m	
8 A6-174	1000/m	
		Wiring interface adaptor integration	
0	No G1/2: standard	
1	G3/4 SUS304	
2	NPT1/2 SUS304	
3	NPT3/4 SUS304	
		Oil-prohibiting treatment*2	
0	No	
1	Yes	
		Mark form	
A	Japanese	
B	Designated English	
		Combined convertor*3	
0	Manufacturing simultaneously	
1	No	

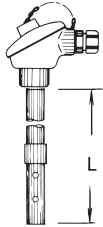

- *1. If the L size is 500 mm above and sample water flow rate exceeds 0.1m/s (standard), the protective pipe for reinforcing the detector needs to be used.
- *2. Oil-prohibiting treatment means cleaning the electrode part in contact with the liquid with ethyl alcohol.
- *3. If not manufacturing simultaneously with the convertor, please notify the model and production No. of combined convertor.

Notes

1. A6 electrode is connector box type, so please order the dedicated cable EC-10 type (outer diameter: φ8). A6-17□ type is immersion type, accessories (prepared or additionally purchased by the customer) need to be installed.
2. Temperature range of sample water is 0 to 100°C, and the pressure is atmospheric pressure.
3. For the high conductivity test range with the cell constant of 10/cm (1000/m), the electromagnetic induction type is recommended.

● Drop-in type A5-17□ type

A51-2-□□□□□ Model		Main material of part (electrode) in contact with liquid	
A	SUS316 : standard	
B	SUS316L	
Z	Special	
		Conductor length (outer diameter: φ5.5)	
1	5 m	
2	10 m	
3	15 m	
4	20 m	
5	25 m	
6	30 m	
9	Special	
		Cell constant *1	
1 A5-171	0.01/cm	
2 A5-172	0.1/cm	
3 A5-173	1/cm	
4 A5-174	10/cm	
		Cell constant (SI unit system) *1	
5 A5-171	1/m	
6 A5-172	10/m	
7 A5-173	100/m	
8 A5-174	1000/m	
		Mark form	
A	Japanese	
B	Designated English	
Z	Special	
		Combined convertor*2	
0	Manufacturing simultaneously	
1	No	



Custom spec. code;
Numeric digit: 9
Alphabet: Z

- *1. It needs to be equal to the cell constant at the convertor side in different test ranges.
- *2. If not manufacturing with the convertor simultaneously, please notify the data of combined convertor (production number, etc.). In addition, if it is made simultaneously, please refer to the ordered convertor additionally.

Notes

1. For the drop-in type conductivity detector, the length of electrode part is 125mm or 150mm (total length: 210 mm, maximum diameter: φ36) and below.
2. The service temperature and pressure range are as shown below.
Temperature: 0 to 55°C
Pressure resistance: 0.1MPa below (water depth: MAX.10m)
3. The tested cell constant of high conductivity is 10/cm (A5-174 type). Bubbles are easy to enter, and the replaceability is poor. It is recommended to use the electromagnetic induction ME-111□ type.

● Flow-through type with stainless steel case (screwed connection) A6-13□ type

A61F-3-	□	□	□	□	□	□	□	□	□	□	Model	
A	Main material of electrode											
B	SUS316: standard											
	SUS316L											
1	Screwed connection specification of stainless steel case											
2	SUS316 RC1/2: Standard											
3	SUS316 RC1/4: BSC integrated correspondingly											
4	SUS316 NPT1/2											
5	SUS316 NPT1/4											
6	SUS316L RC1/2											
7	SUS316L RC1/4											
8	SUS316L NPT1/2											
	SUS316L NPT1/4											
Y	General Y											
Y	General Y											
Y	General Y											
Y	General Y											
	Cell constant											
1	A6-131	0.01/cm										
2	A6-132	0.1/cm										
3	A6-133	1/cm										
4	A6-134	10/cm										
	Cell constant (SI unit system)											
5	A6-131	1/m										
6	A6-132	10/m										
7	A6-133	100/m										
8	A6-134	1000/m										
	Wiring interface adaptor integration											
0	No G1/2: standard											
1	G3/4 SUS304											
2	NPT1/2 SUS304											
3	NPT3/4 SUS304											
	Oil-prohibiting treatment*1											
0	No											
1	Yes											
	Mark form											
A	Japanese											
B	Designated English											
	Combined convertor*2											
0	Manufacturing simultaneously											
1	No											

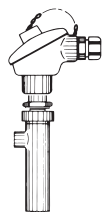

(Stainless steel)

Custom spec. code;
Numeric digit: 9
Alphabet: Z

*1. Oil-prohibiting treatment means cleaning the electrode part in contact with the liquid with ethyl alcohol.

*2. If not manufacturing with the convertor simultaneously, please notify the model and production number of combined convertor.

Notes

1. A6 electrode is connector box type, so please order the dedicated cable EC-10 type (outer diameter $\phi 8$).
2. Temperature range of sample water is 0 to 100°C, and the maximum pressure is 1.0 MPa.
3. For the high conductivity test range with the cell constant of 10/cm (1000/m), the electromagnetic induction type is recommended.

● Flow-through type with a stainless case (flange connection) A6-14□ type

A61F-3-	□	□	□	□	□	□	□	□	□	□	□	Model	
	A												Main material of electrode
	B												SUS316: standard
		B											SUS316L
			Y										General Y
													Stainless steel case flange connection specification*1
		A											SUS316 15A JIS10K RF: standard
		B											SUS316 25A JIS10K RF
		C											SUS316 1/2" ANSI 150LB RF
		D											SUS316 1" ANSI 150LB RF
		W											SUS316 25A JIS10LB RF: WS-21 interchange
		E											SUS316L 15A JIS10K RF
		F											SUS316L 25A JIS10K RF
		G											SUS316L 1/2" ANSI 150LB RF
		H											SUS316L 1" ANSI 150LB RF
		J											SUS316L 25A JIS10LB RF: WS-21 interchange
			Y										General Y
													General Y
													Cell constant
													1 A6-141 0.01/cm
													2 A6-142 0.1/cm
													3 A6-143 1/cm
													4 A6-144 10/cm
													Cell constant (SI unit system)
													5 A6-141 1/m
													6 A6-142 10/m
													7 A6-143 100/m
													8 A6-144 1000/m
													Wiring interface adaptor integration
													0 No G1/2: standard
													1 G3/4 SUS304
													2 NPT1/2 SUS304
													3 NPT3/4 SUS304
													Oil-prohibiting treatment*2
													0 No
													1 Yes
													Mark form
													A Japanese
													B Designated English
													Combined convertor*3
													0 Manufacturing simultaneously
													1 No

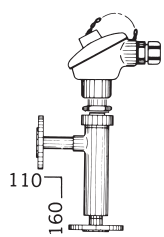

Custom spec. code;
Numeric digit: 9
Alphabet: Z

*1. Even if the flange size is 25A (1"), the pipe size (sample water inlet • outlet pipe diameter) shall be 15A (1/2 ")

*2. Oil-prohibiting treatment means cleaning the electrode part in contact with the liquid with ethyl alcohol.

*3. If not manufacturing with the convertor simultaneously, please notify the model and production number of combined convertor.

Notes

1. A6 electrode is connector box type, so please order the dedicated cable EC-10 type (outer diameter φ8).
2. Temperature range of sample water is 0 to 100°C, and the maximum pressure is 1.0 MPa.
3. For the high conductivity test range with the cell constant of 10/cm (1000/m), the electromagnetic induction type is recommended.

● Flow-through type with a polypropylene case (screw connection) A6-15□ type

A61F-3-	□	□	□	□	□	□	□	□	□	Model	
	A										Main material of electrode SUS316: standard
	B										SUS316L
	Y										General Y
	Y										General Y
	1										PP case screwed connection specification*1 RC1/2: Standard
	Y										General Y
											Cell constant
	1									A6-151	0.01/cm
	2									A6-152	0.1/cm
	3									A6-153	1/cm
	4									A6-154	10/cm
											Cell constant (SI unit system)
	5									A6-151	1/m
	6									A6-152	10/m
	7									A6-153	100/m
	8									A6-154	1000/m
											Wiring interface adaptor integration
	0										No G1/2: standard
	1										G3/4 SUS304
	2										NPT1/2 SUS304
	3										NPT3/4 SUS304
											Oil-prohibiting treatment*2
	0										No
	1										Yes
											Mark form
	A										Japanese
	B										Designated English
											Combined convertor*3
	0										Manufacturing simultaneously
	1										No

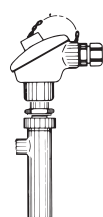

(PP)

Custom spec. code;
Numeric digit: 9
Alphabet: Z

- *1. The finished product has PP case, so the matched screw specification is only limited to Rc 1/2.
- *2. Oil-prohibiting treatment means cleaning the electrode part in contact with the liquid with ethyl alcohol.
- *3. If not manufacturing with the convertor simultaneously, please notify the model and production number of combined convertor.

Notes

- 1. A6 electrode is connector box type, so please order the dedicated cable EC-10 type (outer diameter φ8).
- 2. Temperature range of sample water is 0 to 80°C, and the maximum pressure is 0.3 MPa.
- 3. For the high conductivity test range with the cell constant of 10/cm (1000/m), the electromagnetic induction type is recommended.

● Flow-through type with polypropylene case (flange connection) A6-16□ type

A61F-3-	□	□	□	□	□	□	□	□	□	Model	
	A										Main material of electrode SUS316: standard
	B										SUS316L
	Y										General Y
	Y										General Y
	Y										General Y
	1										PP case flange connection specification 15A JIS10K FF: standard
	B										25A JIS10K FF*1
											Cell constant
	1									A6-161	0.01/cm
	2									A6-162	0.1/cm
	3									A6-163	1/cm
	4									A6-164	10/cm
											Cell constant (SI unit system)
	5									A6-161	1/m
	6									A6-162	10/m
	7									A6-163	100/m
	8									A6-164	1000/m
											Wiring interface adaptor integration
	0										No G1/2: standard
	1										G3/4 SUS304
	2										NPT1/2 SUS304
	3										NPT3/4 SUS304
											Oil-prohibiting treatment*2
	0										No
	1										Yes
											Mark form
	A										Japanese
	B										Designated English
											Combined convertor*3
	0										Manufacturing simultaneously
	1										No

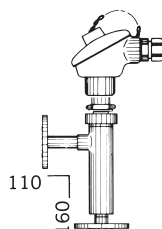

(PP)

Custom spec. code;
Numeric digit: 9
Alphabet: Z

- *1. The dimension of 25A flange face is 110 (W) ×170 (H). Even if the flange size is 25A, the pipe size (sample water inlet, outlet tube diameter) shall be 15A (1/2").
- *2. Oil-prohibiting treatment means cleaning the electrode part in contact with the liquid with ethyl alcohol.
- *3. If not manufacturing with the convertor simultaneously, please notify the model and production number of combined convertor.

Notes

- 1. A6 electrode is connector box type, please order the dedicated cable EC-10 type (outer diameter φ8).
- 2. The temperature range of sample water is 0 to 80°C, and the maximum pressure is 0.3 MPa.
- 3. For the high conductivity test range with the cell constant of 10/cm (1000/m), the electromagnetic induction type is recommended.

AR type detector

Model of AR electrode for small purified water equipment

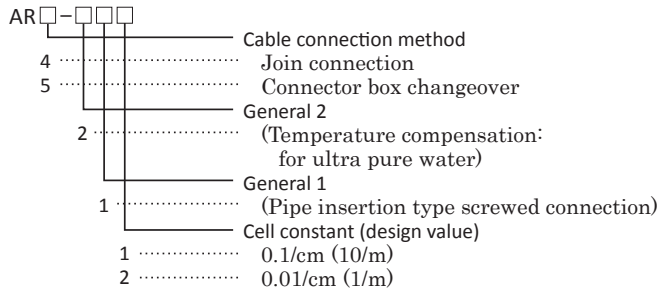

Standard specification

Product name	: Detector for conductivity meter
Model	: AR4-21□, AR5-21□
Cell constant	: About 0.1/cm, about 0.01/cm
Temperature sensing element	: Equivalent to the thermistor at the level of 0.1 (embedded to the internal electrode)
Sample water conditions	: Temperature ...0 to 100°C (no freezing)
Material	: Electrode...titanium Screw assembly...SUS316 (PTFE coating) Sealing...FKM Connector (AR4) ... plastic Connector box (AR5)... aluminum casting
Pipe connection	: R3/4 screwed connection
Heat-resistance temperature	: 0 to 100°C
Dedicated cable (EC-10)	: Outer diameter φ8, Standard length 5m (maximum length; 100m), With connector (anti-dripping structure) (for AR4)

Dimensions Unit : mm

● Screw-in type □AR4-211 type

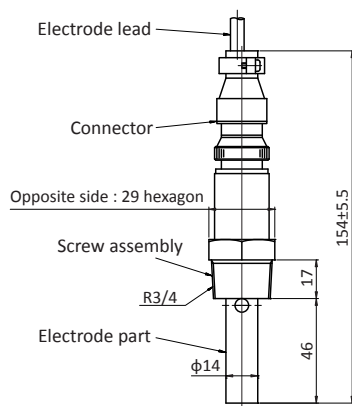

● Screw-in type □AR4-212 type

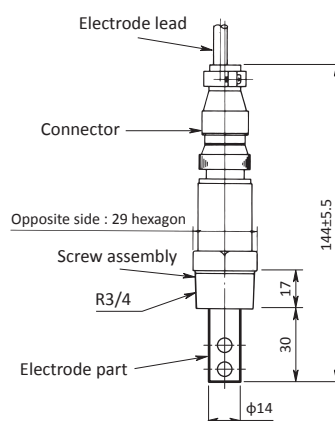

● Flow-through type with case AR4-21□ type

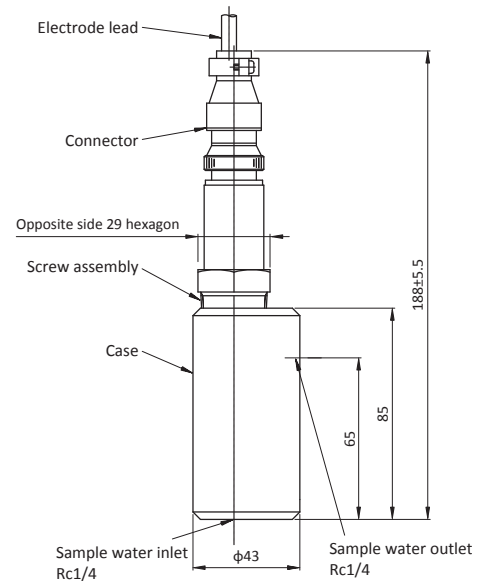

● Screw-in type AR5-211 type

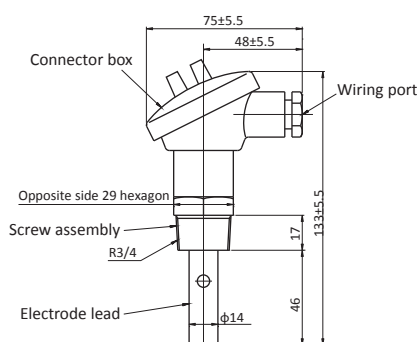

● Screw-in type AR5-212 type

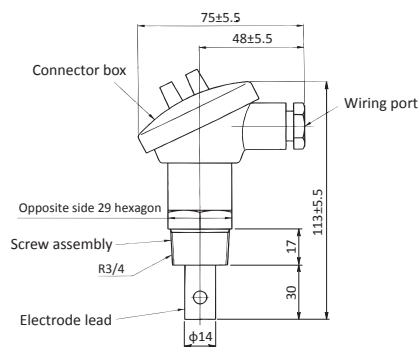

● Flow-through type with case AR5-21□ type

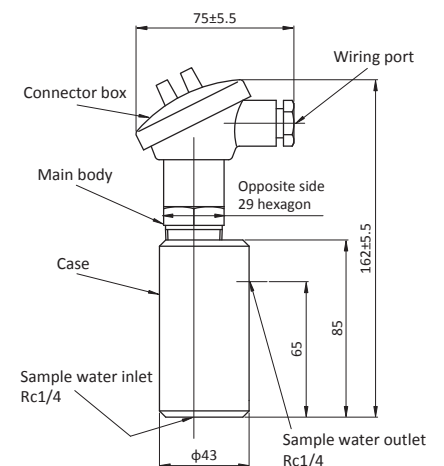

Product code

● AR4 type (connector type)

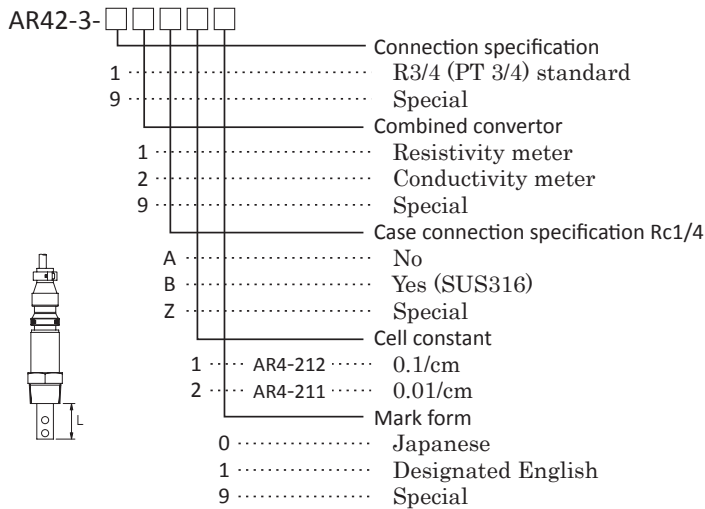

● Dedicated cable EC-10 for AR4 type

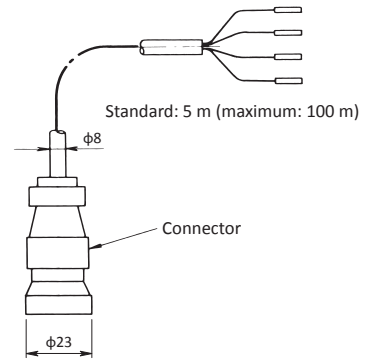

Notes

- L size below screw is different from cell constant.
Cell constant: 0.1/cm - L size: 30mm
Cell constant: 0.01/cm - L size: 46mm
- The electrode is mainly made of titanium. Case(optional) (flow through type chamber) is mainly made of SUS316.
- This is not rainproof structure and not installed outdoor. Please install this indoors
- Sample water conditions: temperature...0 to 100°C pressure...0.5MPa below
- The combined cable is EC-10 type. Please purchase it additionally.

● AR5 type (connector box type)

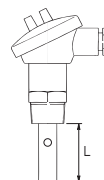
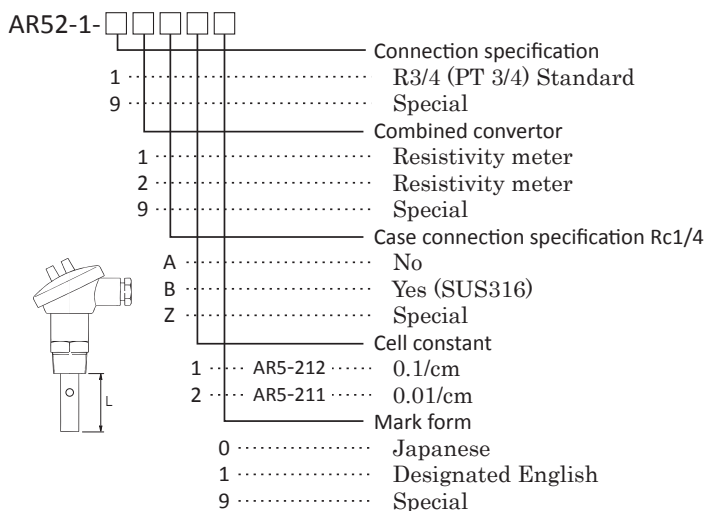

● Dedicated cable EC-10 for AR5

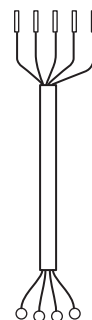

Notes

- L size below screw is different from cell constant.
Cell constant: 0.1/cm - L size: 26mm
Cell constant: 0.01/cm - L size: 46mm
- The electrode is mainly made of titanium. Case(optional) (flow through type chamber) is mainly made of SUS316.
- This is not rainproof structure and not installed outdoor. Please install this indoors.
- Sample water conditions: temperature...0 to 100°C pressure...0.5MPa below.
- The combined cable is EC-10 type. Please purchase it additionally.

■ Dedicated cable

The special cable is used for conductivity meter and between the convertor and detector.

Model	: EC-10
Outer diameter	: $\varphi 8$
Insulating material	: PP and plastic
Casing	: Plastic
Insulation resistance	: $10^5 M \Omega$ above/ 100m between cores
Extended distance	: Maximum 50m, changeover unavailable in the midway
Standard length	: 5m to 50m, in the unit of 5m
Weight	: About 0.5kg/5m

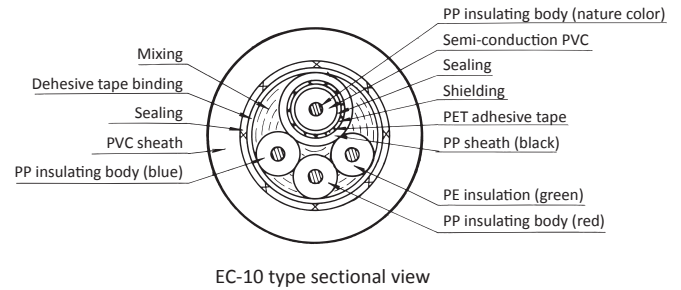

EC-10 type sectional view

■ During installation of conductivity meter detector, please pay attention to the following points.

1. Please install it at the position free from violent vibration and easy to maintain.
2. Install it at the position free from corrosive gas and chemical.
3. Insertion type detector installation method

It is recommended to install the insertion type detector in screw or flange connection at the upper part of horizontal tube. (Figure A)

When it is installed at the side of vehicle pipe, the detector shall be at the horizontal lying position. (Figure B)

If the cell constant is 0.01/cm and 0.1/cm type, the detector can be at the horizontal lying position.

If the cell constant is 1.0/cm and 10/cm type, please incline at the horizontal angle of 45° above during installation. (Figure C)

If the bubbles enter the electrode, bubbles are hard to penetrate. The inclined installation is to make the bubbles easily to penetrate.

(If the bubbles enter, changes will be displayed)

4. Assembly essentials of flow through type with a case. Please install the bypass valve on the bypass tube, and install the stop valve on IN/OUT. (Figure D) You can remove the detector for maintenance by stopping the valve even during equipment operation. In the case of the detector for ultra-pure water, the installed bypass tube shall be as short as possible.

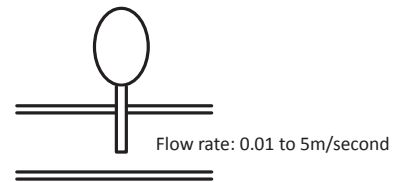

Figure A Horizontal piping, vertical assembly

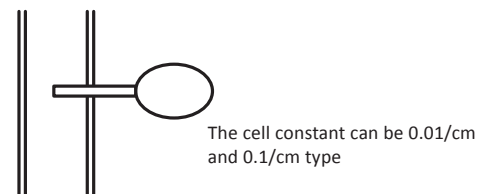

Figure B vertical piping, horizontal assembly

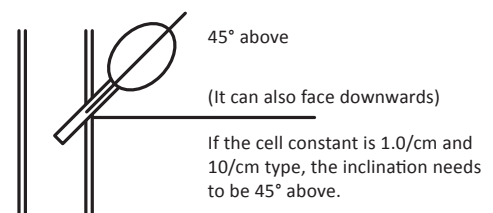

Figure C Vertical piping, inclined installation

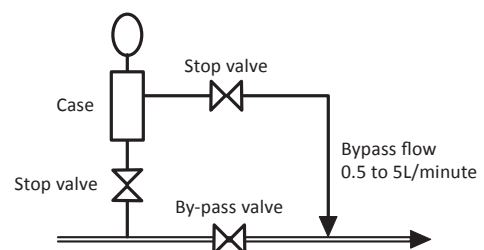

Figure D Mounting the by-pass line for a flow through type detector

■ Combined conductivity meter Transmitters

On-site installation type (2-wire type)/ (4-wire type) WDM-135A / WDM-136A



- Rain-proof structure embedded in the microcomputer, on-site installation type
- Range of changeable transmission output (4 to 20mADC)
- Transmission output value kept in maintenance
- Power supply is double wire type 24VDC 4-wire type 100 to 120VAC
- Corresponding S/cm unit system and S/m unit system
- Measurement range
0 to 20/200/2000 μ S/cm, 0 to 20mS/cm
0 to 2000 μ S/m, 0 to 20/200/2000mS/m

Panel installation type WBM-100 / WBM-210A



- Small DIN96 size
- WBM-210A can be connected with 2 detectors (double channels)
- Range of changeable transmission output (4 to 20mADC)
- Attached alarm contact of lower and upper limits
- RS-232C device (WBM-210A)
- The power supply is 100 to 240VAC free power
- Corresponding S/cm unit system and S/m unit system
- Measurement range
0 to 20/200/2000 μ S/cm, 0 to 20mS/cm
0 to 2000 μ S/m, 0 to 20/200/2000mS/m

On-site installation type (4-wire type) WBM-160



- Practical functions are carried on the solid aluminum die casting
- Transmission output of double circuits (conductivity and liquid temperature) (4 to 20mA)
- Range of changeable transmission output (4 to 20mADC)
- Attached alarm contact of lower and upper limits
- RS-232C (optional) device can be attached
- The power supply is 100 to 240VAC free power supply
- Corresponding S/cm unit system and S/m unit system
- Measurement range
0 to 20/200/2000 μ S/cm, 0 to 20mS/cm
0 to 2000 μ S/m, 0 to 20/200/2000mS/m



DKK-TOA CORPORATION

Overseas Sales Division:
DKK-TOA Corporation
29-10, 1-Chome, Takadanobaba, Shinjuku-ku,
Tokyo 169-8648 Japan
Tel : +81-3-3202-0225 Fax : +81-3-3202-5685
E-mail : intsales@dkktoa.com



CAUTION

Please read the operation manual carefully before using products.