

DISSOLVED OXYGEN ANALYZER/TRANSMITTER

Model: OBM-300

FEATURES

- Suitable for Industrial Environment:**
 Dissolved Oxygen (DO) analyzer for low concentration measurements. Rainproof construction allows the unit to be suitable for field-installation.
 Operation and wiring connections are accessed from the front allowing pole or wall mounting.
- Designed for ease-of-use:**
 Routine operation and calibration can be carried out without opening the enclosure by operating external switches on the front of the instrument. This feature allows routine maintenance to be continued under adverse weather conditions.
- Wide range of functions:**
 A wide range of advanced functions are available including stabilisation judgement during calibration, temperature indication during measurement, high-low limit concentration alarms, sample cut-off (optional), etc.
- Simplified calibration using air:**
 Measurement range is 0~999.9 μ g/L. Simple and reliable span calibration can be carried out using air.
- Low sample consumption:**
 The instrument can operate with sample consumption down to 100mL/min. (when combined with CO-64/65 sensor).

STANDARD SPECIFICATIONS

Product Name	: Dissolved oxygen analyser/Transmitter
Model	: OBM-300
Measurement Object	: Dissolved Oxygen of water (DO) DO saturation ratio of water (in percent with air saturation as 100%) Oxygen gas (O ₂) Temperature (TEMP)
Measurement Method	: Polarographic DO electrode method
Measurement Range	: DO : 0~999.9 μ g/L (or in ppm) SAT : 0~200.0% O ₂ : 0~25.0% TEMP : 0~100°C (no transmission output)
Linearity	: $\pm 1\%$ FS (with equivalent input) at 0~40 μ g/L, $\pm 0.5\mu$ g/L
Repeatability	: $\pm 0.8\%$ FS (with equivalent input) at 0~40 μ g/L, $\pm 0.3\mu$ g/L

SYSTEM CONFIGURATION

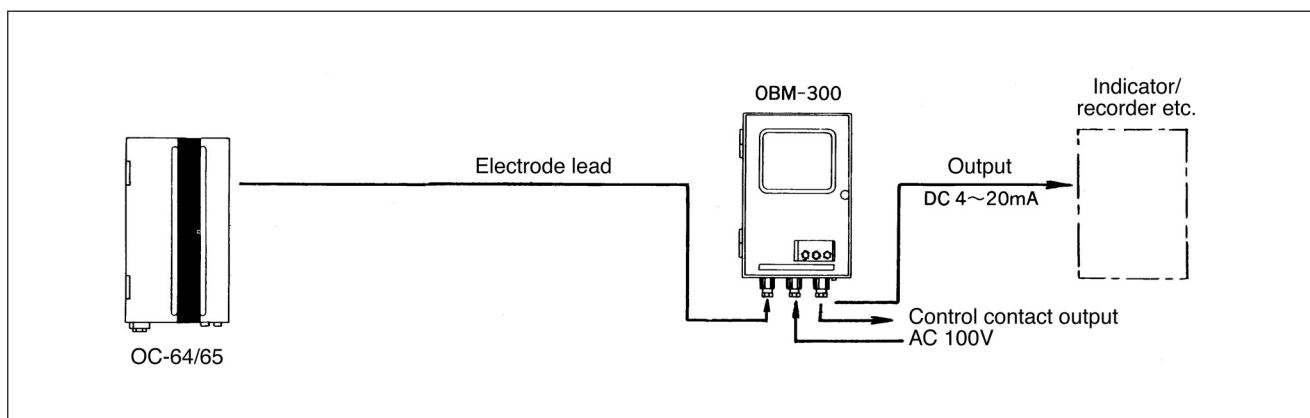

Temperature Compensation

Compensation range : 0~45°C
 Compensation accuracy : within $\pm 2\%$ FS (with equivalent input)

DO Detecting Sensitivity

: $\pm 1\mu$ g/L

Indication

: Digital, 4-digit LCD

Output

: 4~20mA DC, corresponding to measured value. Max. load resistance 600 Ω , isolated from input.
 One item out of DO, SAT, O₂ is selected by key operation.

(1) DO

Range switching; One of the below is set by keying.

(a) Manual switching; No.1~No.3 range is selected from keypad.

(b) Auto switching. Range shifts up at 100% of present range, and shifts down when measured value drops to 90% FS of the next lower range.

(c) Remote switching; By remote range switching contact input.

Output range; setting by keying in the following range.

No.1 range; 0~Tf μ g/L (Tf: within 20~200 μ g/L range at 10 μ g/L unit value)

No.2 range; 0~Tf μ g/L (Tf: within 200~1000 μ g/L range at 10 μ g/L unit value)

No.3 range; 0~20mg/L (ppm indication is also possible).
(fixed)

(2) SAT.
Output range; 0~200% (fixed)

(3) O₂
Output range; 0~25% (fixed)

Control Functions

Set value : High/low limits of output are set and detected for the selected item.
(1) DO; 0~999.9µg/L.(Setting at 0.1µg/L step is possible).
(2) SAT; 0~200.0% (Setting at 0.1% step is possible).
(3) O₂; 0~25% (Setting at 0.1% step is possible).

Type of circuit : Electronic alarm circuit (digital comparison).

Number of circuits : 2 circuits of high and low limits, contacts (each contact is open during maintenance, and when power is OFF).

Contact capacity : 250V AC, 3A

Dead zone : (1) DO; 0.0~10.0µg/L.(Setting at 0.1µg/L is possible.)
(2) SAT; 0.0~5.0% (setting at 0.1% step is possible).
(3) O₂; 0.0~1.0% (Setting at 0.1% step is possible).

Note:

Install a surge limiter to the load to be connected for noise protection and protection of contacts.

Analyzer Fault Alarm : Common contact switching output for power cut off, sample cut off or abnormal measured temperature

Contact Rating : 125V AC, 1A (resistive load)

Meas. Range Indication : Make-contact output corresponding to output range (One terminal is used in common).

Contact Rating : 125V AC, 1A (resistive load)

Input Signal : Remote range switching contact input. Make-contact input (One terminal is used in common). No.3 range is used when all terminals are open.

Contact Rating : 50V DC, 0.1A or more

Calibration : Zero calibration; Open input or 5% Na₂SO₃

Span calibration : Air or air saturated water

Ambient Temperature and Ambient Humidity : -10~55°C, 95%(RH) or less

Power Requirements : 90~132V AC, 50/60Hz (other operating voltages available as options)

Power Consumption : Approx. 10VA

Construction : Outdoor installed, rainproof

Mounting : 50A (2 inch, outer diameter 60.5mm) pipe mount or wall mount

Materials

Main body : Aluminium die cast and glass (window)

Surface Finish : Pantone 537C (equivalent to Munse11 5PB8/1)

Cable Port : 6 glands for 6~12 outer diameter cable (Conduit threads G1/2 when cable gland is removed).

Weight : Approx. 5kg

Miscellaneous

(a) Thermal cut off function:

For electrode protection, measurements other than temperature are paused when the measured temperature exceeds 50°C and abnormal signal is delivered. (Indication = 0, Transmission = 40mA)

(b) Measurement/maintenance mode switching function:

When in maintenance mode, output is selected by keying out of "Holding immediate value", "Dummy" and "Tracking".

(c) Sample cut off sensing function:

Measurements other than temperature measurement are paused when sample is cut off, and "abnormal" signal is delivered.

(Indication = 0, Transmission = 40mA)

*Note: Sample cut off signal is unavailable when OC-64 sensor is combined.

(d) Use of exclusive cable is recommended for connection between instrument and sensor. Install away from electrical noise sources.

RELATED EQUIPMENT

Applicable electrode : 7535L

Sensor : OC-64 or OC-65

Extension cable : EC-21

DIMENSIONS

Units: mm, general tolerance: ±5mm

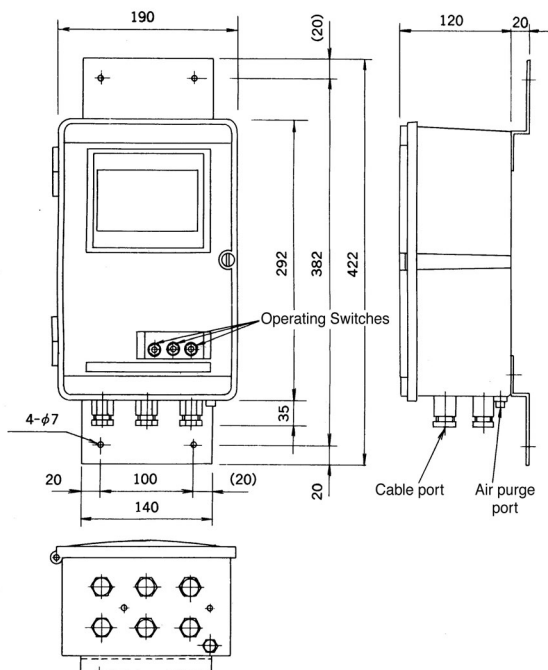

TERMINAL CONNECTION

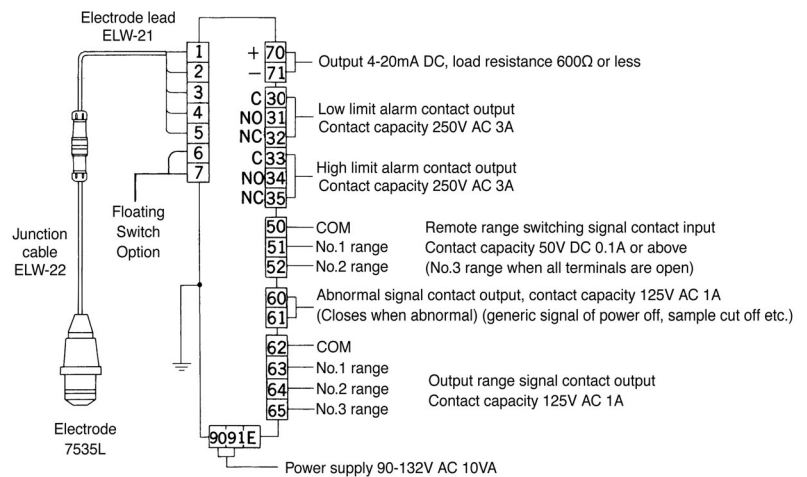

DO SENSOR FOR PURE WATER MEASUREMENT

Models: OC-64/65

FEATURES

- Suitable for measuring boiler water at power plants.
- Used sample is discarded for accurate measurement.
- Only a small quantity of sample is required.
- Model OC-65 is equipped with a sample cut off sensor.

STANDARD SPECIFICATIONS

Product Name	: DO sensor for pure water measurement
Model	: OC-64/65 (option) Float-switch for detecting water cut-off internally installed.
Sample Conditions	: Temperature; 0~45°C, Flow rate; within 100~300mL Pressure; input = below 0.05 MPa output = open to air
Sample Connections	: Rc1/4 (Sample inlet, sample outlet)
Applicable Electrode	: 7535L, lead ELW-21
Ambient Temperature	: 0~40°C/90%RH or less
Ambient Humidity	: 0~40°C/90%RH or less
Weight	: Approx. 4kg
Dimensions	: 220(W) x 80(D) x 400(E) mm. Refer to dimensional drawing.
Mounting Materials	: Wall mount, or 50A pipe mount
Case	: PVC (SPCC)
Measurement cell	: Heat resistant PVC
Tubing	: Nylon
Construction	: Rainproof (JIS CO920)
Paint colour	: Metallic silver and blue

OPTIONS

- 20~200mL/min flow meter (contained)
- Flow rate adjusting needle valve (external)
- 50A pipe bracket (external)

Notes:

Ensure that the sample flow rate constant within 100-300mL/min. Install a cooler and reducer valve when the sample is at high temperatures or high pressures.

FLOW SCHEMATIC

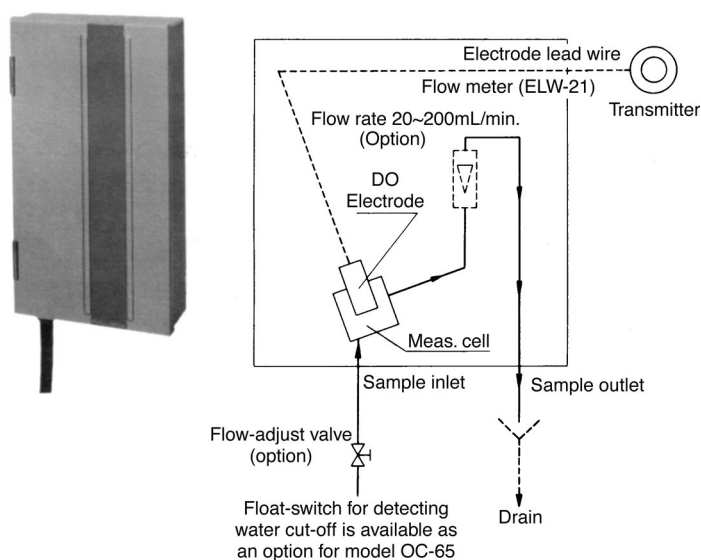

DIMENSIONS

● OC-64 (Back view)

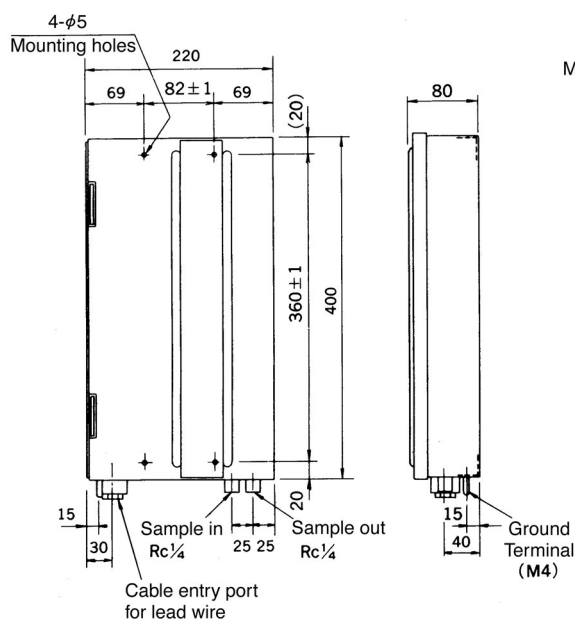

● OC-65 (Back view)

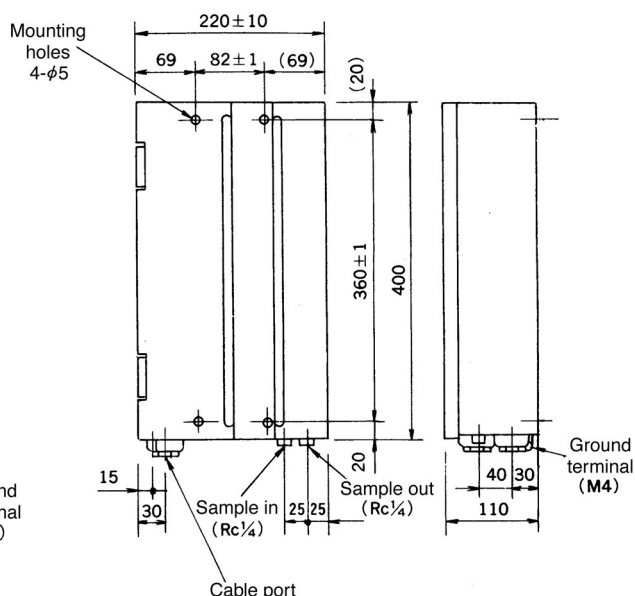

DISSOLVED OXYGEN ELECTRODE FOR LOW CONCENTRATION Model: 7535L

FEATURES

- Membrane polarographic type DO electrode
- Safe and harmless KCl solution used as the electrolyte.
- Excellent durability.

STANDARD SPECIFICATIONS

Model	: 7535L (Leadless type)
Construction	: Polarographic, regenerative type (replaceable membrane and electrolyte)
Application	: Combined with inline or OC-64/OC-65 flow cell type sensor in pure water, power, and foodstuff plants.
Major Materials	: SUS316, polysulfone, teflon
Service Temperature Range	: Sample; 0~45°C, Ambient -5~50°C
Service Pressure	: Max. 5kg/cm ²
Measurement Range	: 0~20μg/L to 0~1mg/L
Sensor Low Limit	: ±1μg/L (ppb)
Responsiveness	: 90% response, 120 sec (25°C)
Applicable Sensor	: OC-64 or OC-65
Applicable Lead Wire	: ELW-21 (for junction ELW-22)

PRODUCT CODE

O	B	M	3	0	0	-					
											Power supply *1
				1	90~132V AC 50/60Hz
				2	180~264V AC 50/60Hz
											Transmission output
				1	4~20mA DC
				2	1~5V DC
											Measurement range *2
				1	0~999.9μg/L
				8	Custom spec.
											Mounting bracket
				A	50A pipe mount
				B	for wall mount
				Z	Custom spec.
											Adapter for cable port *3
				0	Standard (for cable glands of φ6~φ
				1	G1/2 (PF1/2)
				2	NPT1/2
				9	Others
											Hood *4
				0	Nil
				1	Equipped
				9	Custom spec.
											Markings
				0	Standard (Japanese)
				1	English
				9	Custom spec.

*1. AC90~132V or AC180~264V, multi-voltage power supply.

- *2. Measurement and available ranges:
- DO: 0.0~999.9μg/L [μg/L selectable display] (Span calibration range 0.0~20.00μg/L).
 - SAT: 0.0~200.0%.
 - O₂: 0.0~25.0%.
 - TEMP: 0~100°C [Indicated on sub-display, no output].

Outputs:

- DO: First range: 0~(20~200)mg/L, 10mg/L unit, free setting.
 Second range: 0~(200~1000)mg/L, 10mg/L unit, free setting.
 Third range: 0~20.00mg/L, (Fixed; monitor range).
- SAT: 0.0~200.0%.
- O₂: 0.0~25.0%.

Range selection (selectable from the following for DO):

- Automatic 2 ranges (first range <-> second range).
- Automatic 3 ranges (first range <-> third range).
- Remote range selection (specify from the first, second or third range according to the contact point input).
- Manual range selection (select from the first, second or third range by key operation).

- *3. Cable entry specifications are as follows:
- Standard: Cable gland (for Δ6~Δ12), 6 ports.
 - G1/2: Remove the cable gland which is conduit pipe laying and use G1/2 screw.
 - NPT1/2: Remove the cable gland, which is conduit pipe laying and screw in the attached NPT1/2 adapter (5 pieces).
- For non-standard cable entries, holes that are not used will be sealed with standard cable glands to prevent ingress of dust etc.

*4. Hood for protection from direct sunlight is required when the equipment is installed in locations where the ambient temperature is greater than 45°C or the instrument is under direct sunlight.

Note 1. Includes temperature alarm (upper and lower limit), range display signal and error signal, temperature error etc. However, if "no-sample" diagnostic sensor is required, only Model OC-65 includes this function.

Note 2
The combination sensors are the models OC-64 and OC-65.

DKK-TOA CORPORATION

International Operations:
 DKK-TOA Corporation
 29-10, 1-Chome, Takadanobaba, Shinjuku-ku, Tokyo 169-8648 Japan
 Tel: +81-3-3202-0225 Fax: +81-3-3202-5685



CAUTION

Do not operate products before consulting instruction manual.