

Lift-up immersion type · water sampling Type

pH METER WITH AUTOMATIC CALIBRATION FUNCTION

MAC-1600

The MAC-1600 is a field-installation pH meter that automates electrode cleaning and two-point calibration using JIS standard solutions.

In addition to reducing troublesome maintenance work, it is possible to measure pH with high reliability over a long period of time.

In addition to the 2-channel measurement function, which controls two detectors with a single converter, it can be used for pH control or monitoring in various plant facilities

Features

1. Labor saving in maintenance work

Clean the electrodes and calibrate the standard solution periodically. This helps to save labor for maintenance work. It also greatly reduces the burden of maintenance work in hazardous locations and locations with poor environments.

2. Reliable pH measurement

Automatically performs two-point calibration with JIS-standard solution pH7 and pH4 or pH9. Since it is performed with high accuracy, stable and reliable pH monitoring and pH control can be continued for a long period of time.

3. Supports 2-channel measurement (optional)

By simultaneous measurement of two channels connecting two detectors (including the liquid feed control unit) measurement without missing is possible even during calibration and cleaning. The automatic transmission output switching function is effective for the same sample measurement.

- (1) Fixed ch1 preferred (automatically switched to ch2 during cleaning and auto calibration.)
- (2) Fixed ch2 preferred (automatically switched to

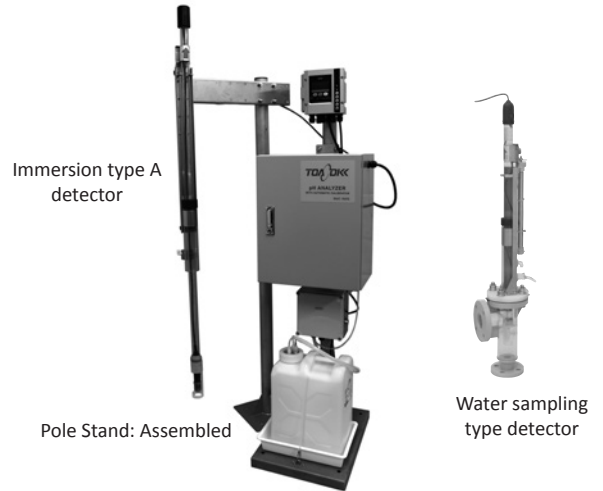

ch1 during cleaning and auto calibration.)

- (3) Alternate switching (priority output of the channel that was last cleaned and calibrated)
- (4) Electrode performance priority (Electrode soundness is compared every calibration, and good channel is given priority output)

4. Three types of electrode variations

In addition to the 5600 series electrodes, which have been proven in the past, tip replaceable electrodes and digital electrodes (CALMEMO-pH), has been included to the lineup. The optimum pH electrode can be selected according to maintainability and site conditions.

5. Lift-up type aerial jet cleaning with high cleaning efficiency

The electrode holder is pulled up from the sample water by an air cylinder. The water is released and high-pressure wash water is injected into the electrode sensitive part in the air. It is a cleaning method with low pressure loss and high jet effect. In addition, since the chemical solution does not come into contact with the sample water in the same way, there is no concern of a decrease in the effect due to dilution.

Configuration Diagram

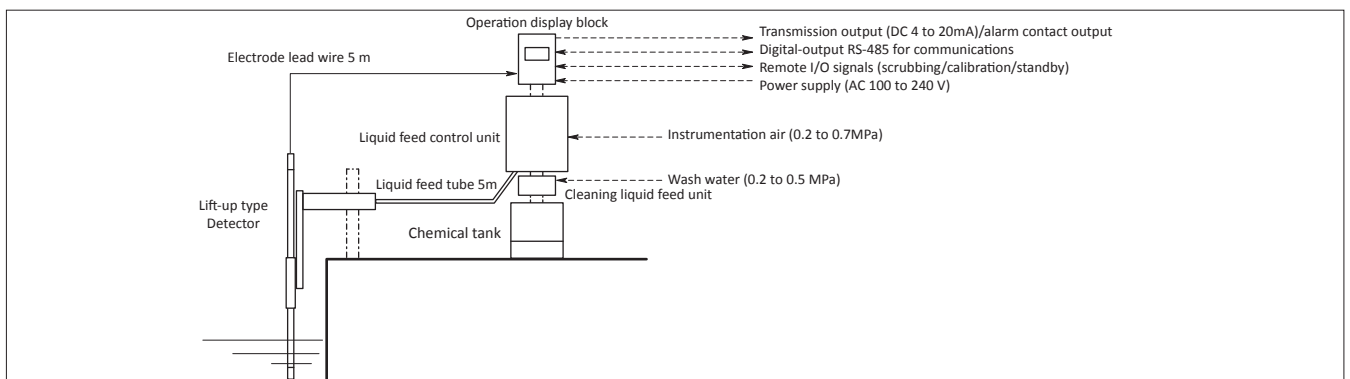

6. Simple and reliable lift-up airborne calibration

Following automatic cleaning, in the same manner in the air, two types of pH standard solutions are sequentially washed. Feed liquid to the electrode sensitive part and contact it with the number. Since there is no risk of contamination with sample water or washing water (chemical liquid), stable and reliable automatic calibration can be performed in a short time (about 10 minutes). In addition, the time required for interchangeable-tip electrodes and CALMEMO-pH electrodes can be reduced by approximately three minutes.

7. Appropriate and practical self-diagnosis message

If calibration is impossible or an electrode is damaged, it outputs collective signal as "instrument failure." At this time, 18 types of error messages on the instrument can be corrected properly.

In addition, three types of alarm signals are output as "maintenance required" when electrode fouling, standard solution shortage, or cleaning chemical shortage occurs, so appropriate maintenance can be performed when necessary.

8. Remote functions for plant automation

Automatic cleaning and calibration can be started with the calendar timer in the instrument. It can be performed with a start signal from the control room and outputs an answer signal during cleaning or calibration. In addition, it is possible to issue a directive for the standby operation to lift up the electrode so that it will not get dirty when the plant stops, and it outputs an answer signal during standby.

9. Holder washing function

Holder cleaning function allows chemical cleaning of electrode holder as well as the electrode.

Standard Specification

Product Name	: pH meter type with automatic calibration function	Non-voltage "Closed" contact is output when alarm message A4 occurs.
Model	: MAC-1600	Cleaning solution shortage signal;
Measurement object	: pH of solution (hydrogen ion concentration)	no-voltage "Close" contact is output when alarm message A5 occurs
Measurement method	: Glass electrode method	Contact capacity; AC 250V 1A, DC 30V
Measuring range	: pH -1.00 to 15.00 (mV; -800.0 to 800.0 temperature; -5.0 to 105.0°C)	1A resistive load
Display	: Liquid crystal digital (with backlight) Minimum display 0.01pH (Temperature; 0.1 mV;0.1)	Control contact input : Automatic calibration start signal; Calibration starts with "Closed" contact input of 100 mS or more Automatic cleaning start signal; Cleaning starts with "Closed" contact input of 100 mS or more Standby command signal; standby operation with no voltage status "Closed" contact input
Analogue output	: DC 4 ~ 20mA I/O isolation type, 2-output load resistor 650Ω or less Output width arbitrarily set; pH..At least 5pH wide in 0.01pH units (Set to 0.00 to 14.00 at shipment) Temperature..At least 40°C wide in 0.1°C unit (Set to 0.0 to 100.0°C at shipment) Output hold setting; Transmission output of last value or arbitrarily value is set to hold at automatic cleaning, automatic calibration, or maintenance (standby) mode (set to hold immediately before at shipment)	Control contact output : Calibration in progress signal; no-voltage "Close" contact is output during automatic calibration Cleaning in progress signal; outputs no-voltage "Close" contact during automatic cleaning. Standby (maintenance in progress) signal; no-voltage "close" contact is output during standby mode (maintenance mode in progress) Contact capacity; AC 250V 1A, DC 30V 1A resistive load
Digital-output	: RS-485 (insulation type), Modbu(s RTU)	Electric power Source : AC 100 to 240V±10% 50/60Hz Power consumption; 1 channel AC 100V approx. 10VA, approx. 30VA at auto calibration AC 240V approx. 15VA, approx. 35VA at auto calibration
Alarm contact output	: Instrument failure signal; error messages E1 to E42 Outputs no-voltage "Closed" contact when it occurs Power-off signal; no-voltage "Close" contact at detection output. Electrode alarm signal; no-voltage "Close" contact is output when alarm message A1, A2, A3, A6 occurs. Standard solution shortage signal;	Features : Linearity; ±0.03pH (at equivalent input) Repeatability; ±0.02pH (at equivalent input)

Temperature compensation range	: 0 to 100°C (temperature characteristics of the glass electrode are automatically compensated in combination with the temperature compensation electrode)	Material Quality	: Operation display; Aluminum casting Liquid feed control unit; SPCC Detector; SUS304, PVC, polypropylene
Automatic calibration method	: Lift-up type standard liquid drip calibration Calibration point; 2 points (JIS standard solution used for pH7 and pH4 or pH9) Calibration cycle; 0 to 240 hours (set to 48 hours when shipped). Set the Year/Month/Day of calibration Calibration time; Approximately 7 to 10 minutes (when the pH electrode characteristics are normal) Calibration solution tank capacity; 2 pieces of 5 L tank (Supply cycle; Approximately every other day per month of automatic calibration)	Painting Color	: Operation display; Metallic silver Liquid feed control unit; Munsell 5Y7/1
Automatic cleaning method	: Lift-up type water / chemical jet intermittent cleaning Cycle; 0 to 24.0 hours (installed at 6.0 hours when shipped) Set the Year/Month/Day of cleaning Cleaning time; Approx. 4 minutes Chemical solution for cleaning; 5% hydrochloric acid Tank capacity; 20 L Consumption; Approx. 100mL/1 time	Supply air	: Instrument air Pressure; 0.2 to 0.7MPa Consumed; Approximately 20L/ cleaning and calibration Port; Rc 1/4 (with air filter)
Standby action	: Lift-up type intermittent water injection (Prevents electrode fouling and dryness) Command method; manual (field) or remote Water injection cycle; 1 to 180 minutes (set to 10 minutes when shipped)	Supply washing water	: Tap water (industrial water is allowed) Pressure; 0.2 to 0.5MPa Consumed; 10 to 20L/ wash and calibration Connecting port; Rc 1/2 (provided with Y type strainer 40 mesh)
Combination pH electrode (Specified at shipment)	: 5600 type (standard) or 5601 type with 5m lead wire GSS-314B type (tip replaceable) with 5m lead wire ELP-103 type (CALMEMO-pH) Digital ample cable with ELW-072 type lead wire of 5m	Cable connection port	: Cable gland for O.D. 6 to 12mm 5 pcs. (Wire conduit connecting screw G 1/2 when cable gland is removed)
Sample Water pH Temperature Compensation	: Compensate pH values for sample water with a known pH temperature coefficient Temperature compensation range; 0 to 100°C Converted temperature 25°C Temperature coefficient setting range; -0.100 to +0.100 pH/°C	Sample water conditions	: Temperature; 0 to 60°C (up to 80°C for high temperature specifications) Pressure; Atmospheric pressure Flow velocity; 1 m/sec or less Electrical conductivity; 10 mS/m (100µS/cm) or more Ambient
Structure Production	: IP54 (JIS C 0902 dust-proof type) In the case of outdoor installation, rain-proof and sun-proof measures (roof) are necessary	Temperature/humidity	: 0 to 50°C 95%RH or less (no condensation)
Mounting	: Operating display/liquid feed control; 50A pole or wall/rack mounting Detector; 50A pole or flange-mounted immersion type, flange-connected water sampling type	Mass	: Operation display; Approx. 2.6kg Liquid feed control unit; Approx. 23kg Cleaning unit; Approx. 3.8kg Detector (Type A); approx. 6kg

Option

Sunshade	: Prevents overheating inside the transducer and liquid feed section due to direct sunlight in the case of outdoor open-air installation
Chemical tank cover	: Prevents deterioration of polyethylene tank caused by ultraviolet rays. The liquid feed tube is also a PFA tube with excellent weatherability.
Soda lime unit	: When using pH9 reference solution for span calibration it prevents oxidization due to airborne CO ₂ .
Standard Solution Heating Unit	: Warms the standard solution in the liquid feed section in winter to maintain high calibration accuracy.
Mounting bracket for deep tank	: Mounting bracket for use with special specifications is available for immersion type detection for deep tank of 1m or more to the water surface

Calibration operation

<Example of GSS-314B (tip replaceable)>

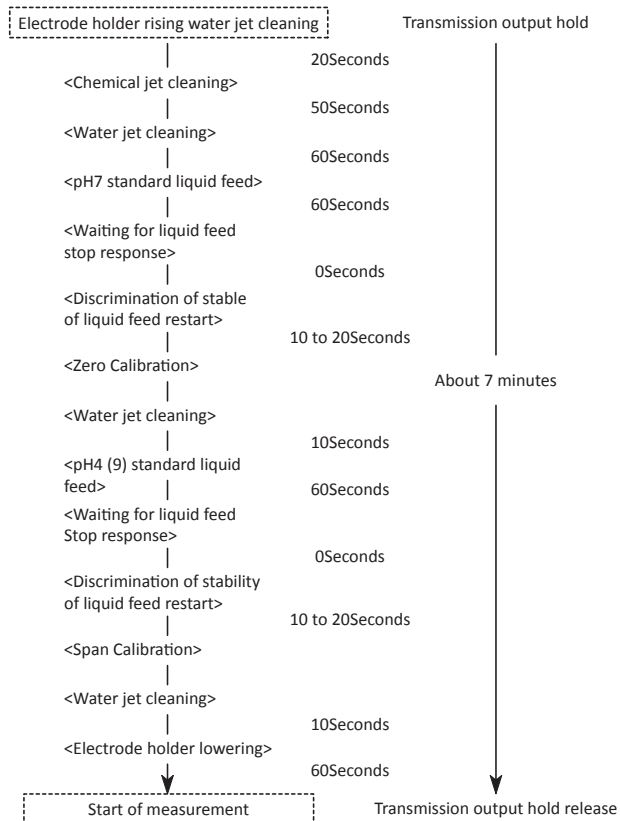

Content of alarm and error messages

Alarm message (sub display)

A1	Calibration zero value is close to the normal limit. Corrective action: Clean the electrode and replace the internal solution (KCl).
A2	Calibration slope value is near the normal limit. Corrective action: Clean the electrode.
A3	Calibration Zero and Slope Values Near Normal Limit. Corrective action: Clean or replace electrode with new one.
A4	Standard solution is low. Corrective action: Replenish the standard solution.
A5	Cleaning liquid (chemical liquid) is low. Corrective action: Replenish the cleaning liquid (chemical liquid).
(A6)	pH indication difference monitoring function is enabled and indication difference between 2 channels is large. Corrective action: Refer to "Electrode alarm (A1, A2, A3)".

Error Message

E1	Zero calibration value error
E2	Span calibration value error
E3	Zero/span calibration value error
E4	Abnormal standard liquid temperature
E5	Stable discrimination error
(E6)	(Failure during cleaning)
(E10)	(Glass electrode failure)
(E11)	(Comparison electrode failure)
E12	Electrode temperature-compensation failure
E20	Memory error "Operation display: MC"
E21	Memory error "Liquid feed control unit: FC"
E22	Setting data error "Operation display: MC"
E23	Setting data error "Liquid feed control unit: FC"
E30	Liquid feed control section failure
E31	Liquid feed control section communication error
(E40)	(CALMEMO not connected or abnormal)
(E41)	(Digital amplifier cable failure)
(E42)	(Digital amplifier cable disconnected)

Names of parts

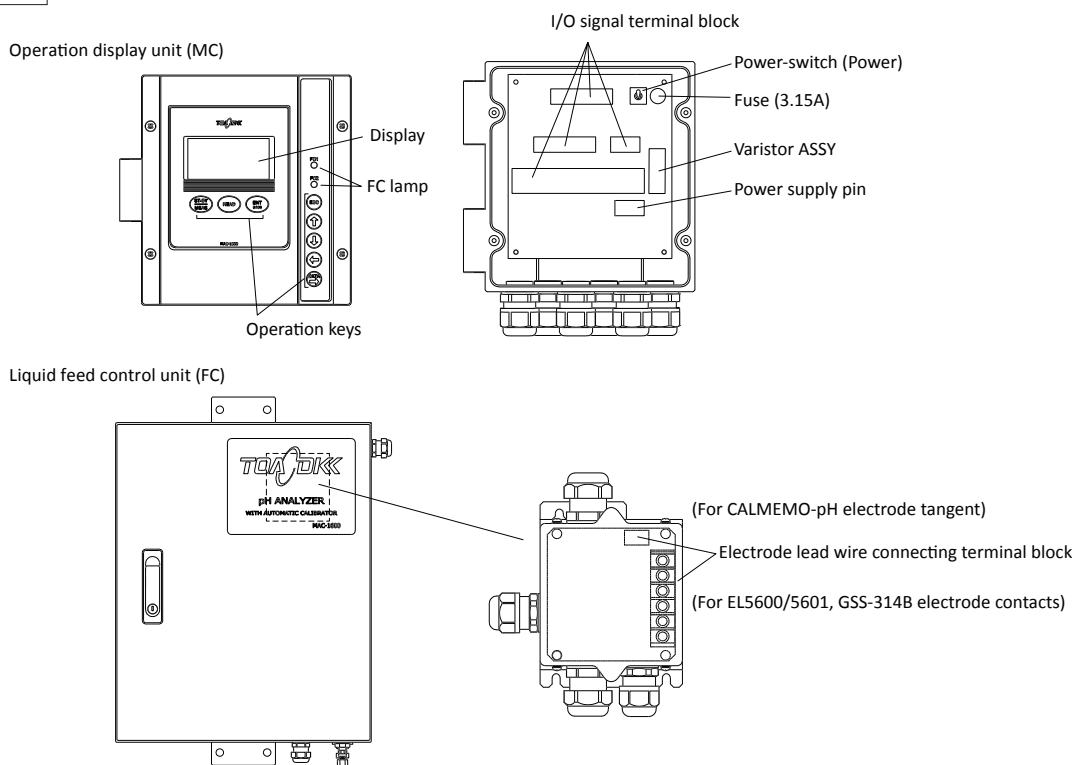

Dimensions

Unit : mm

● Main unit

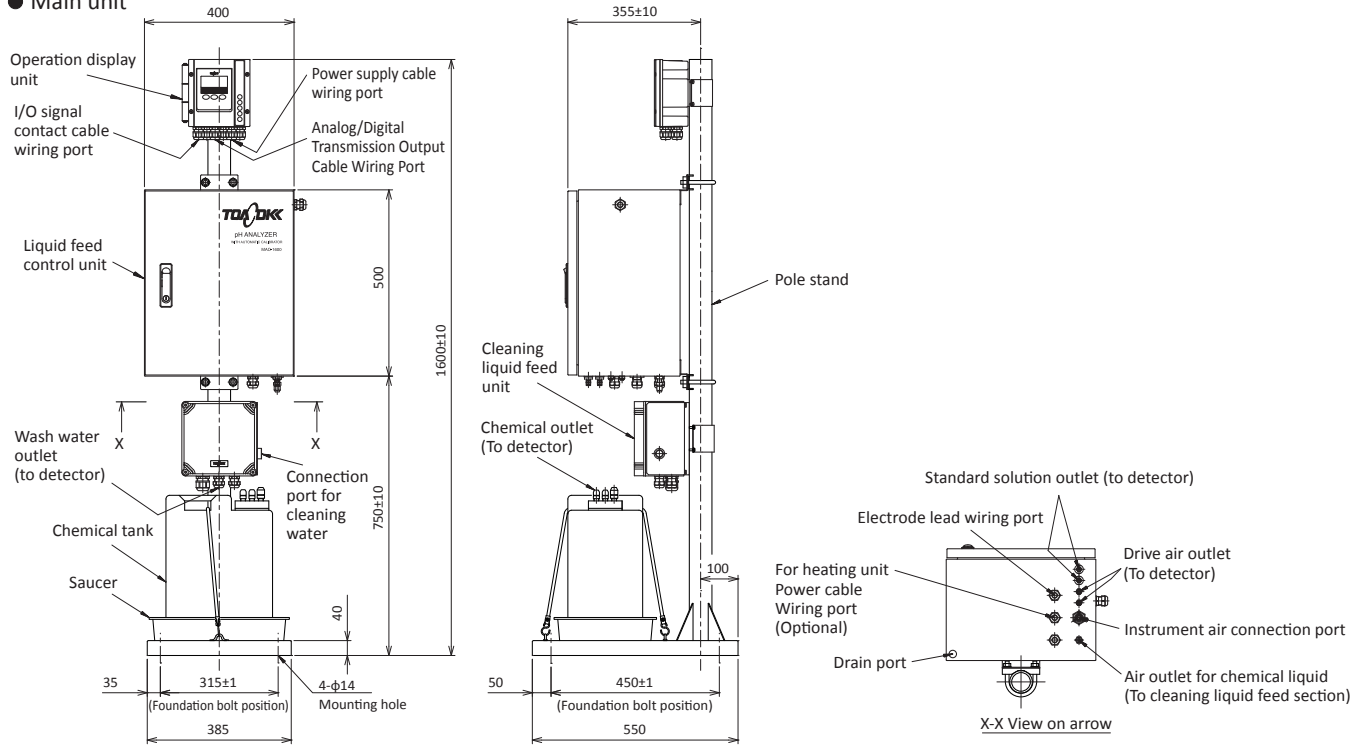

● Immersion type vessel Type A

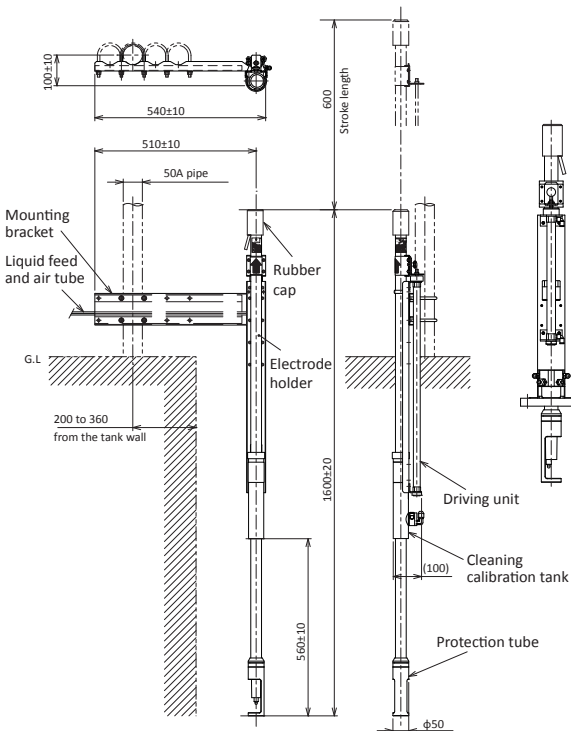

● Immersion type vessel Type B

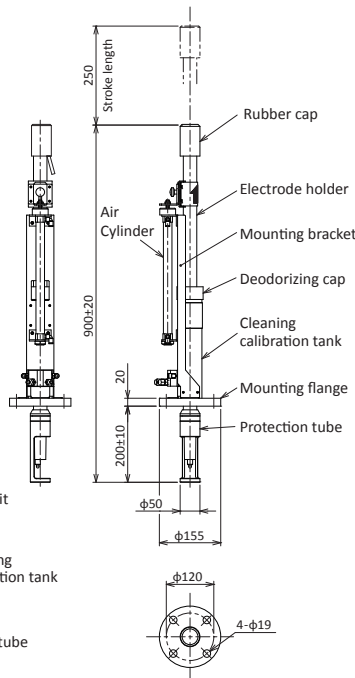

● Water sampling type detector

<Example of GSS-314B type (tip replaceable type)>

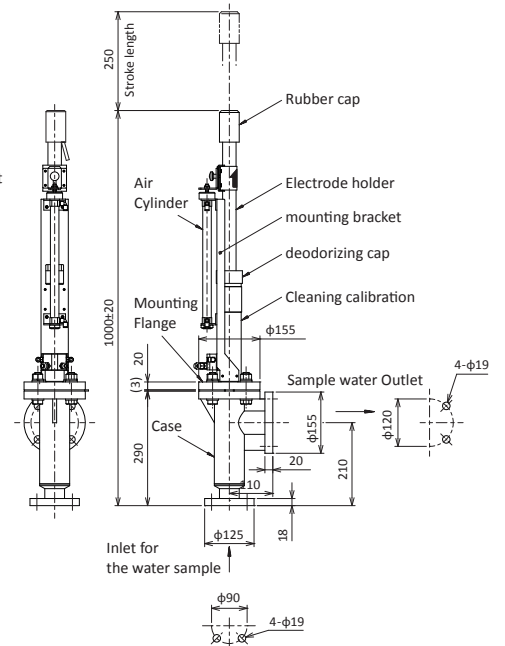

Flow sheet

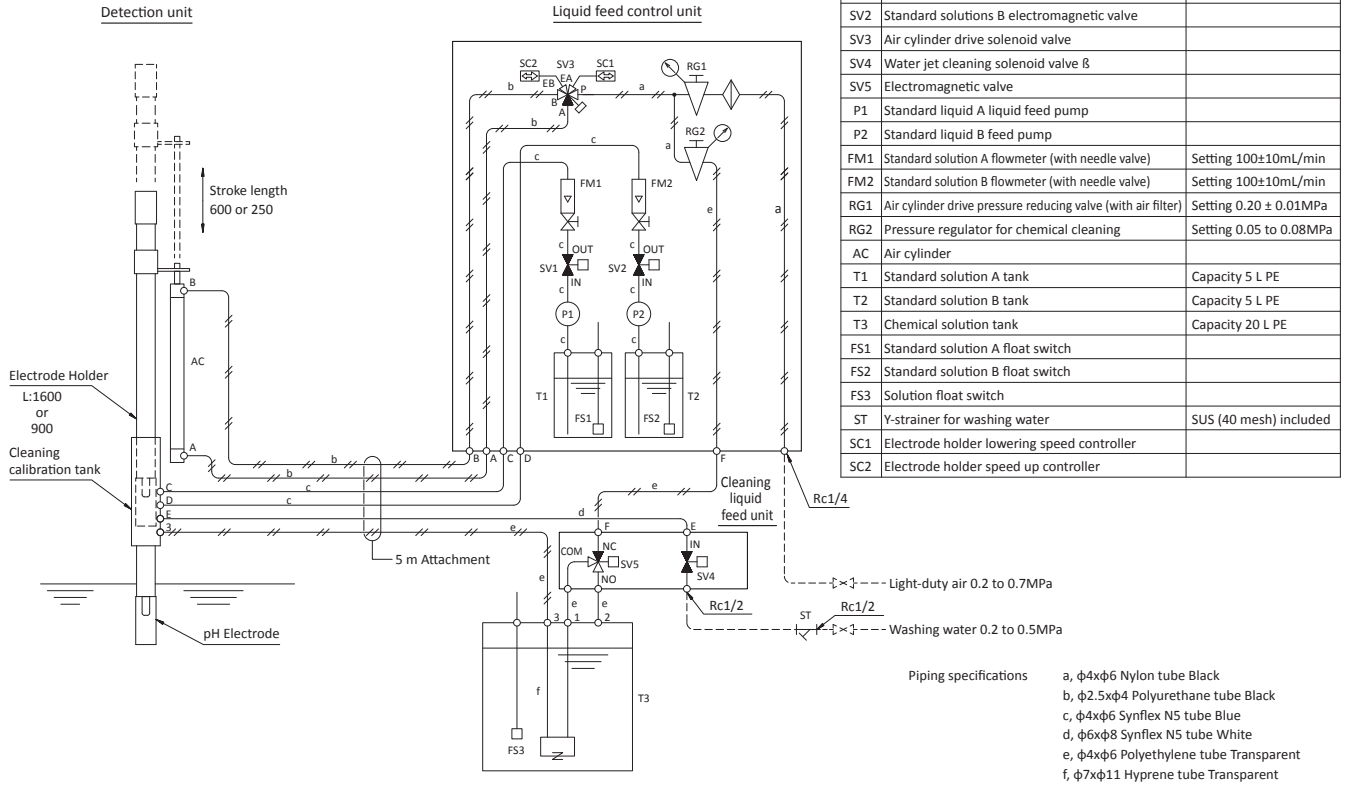

Terminal connection diagram

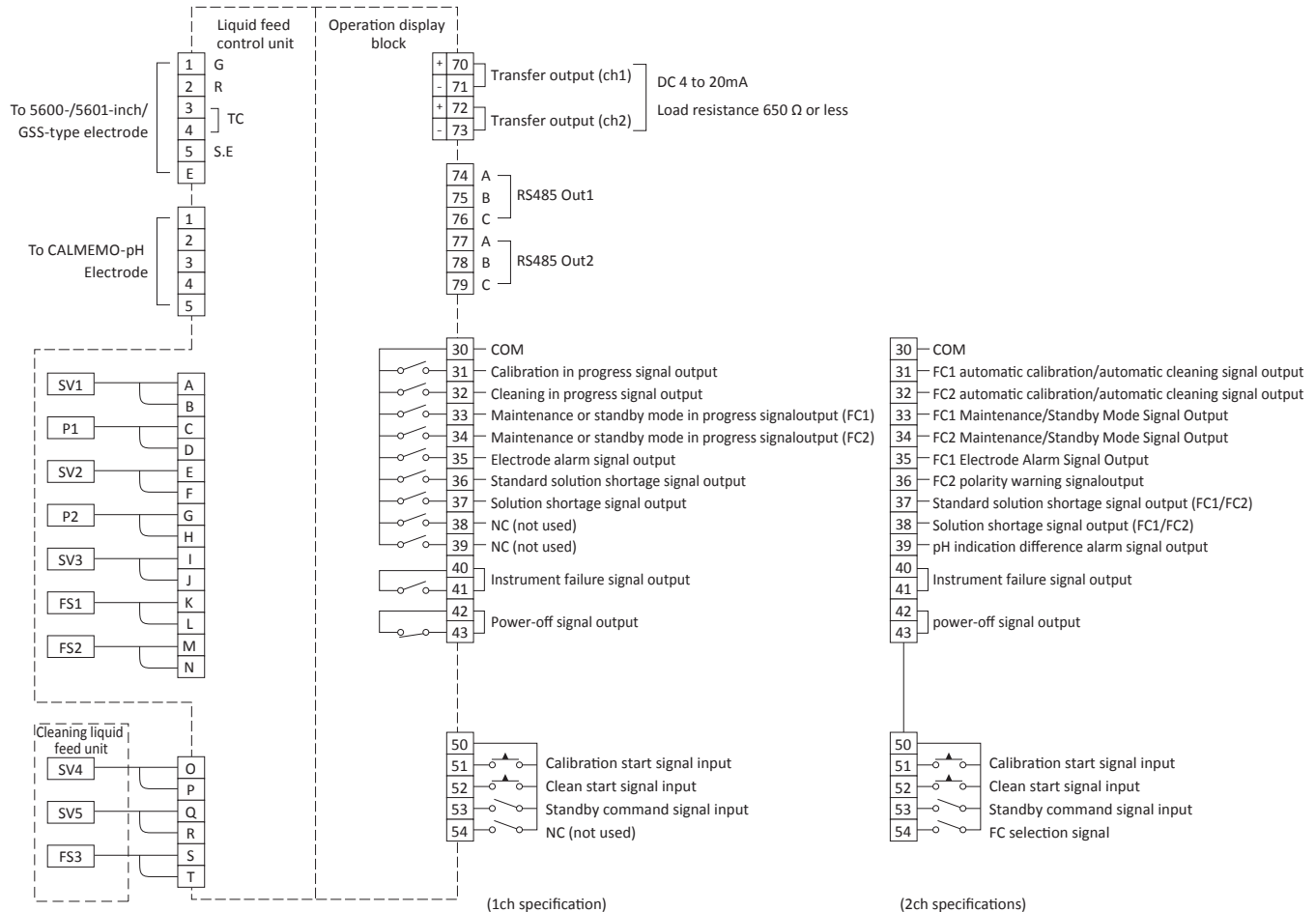

Installation

● Main unit

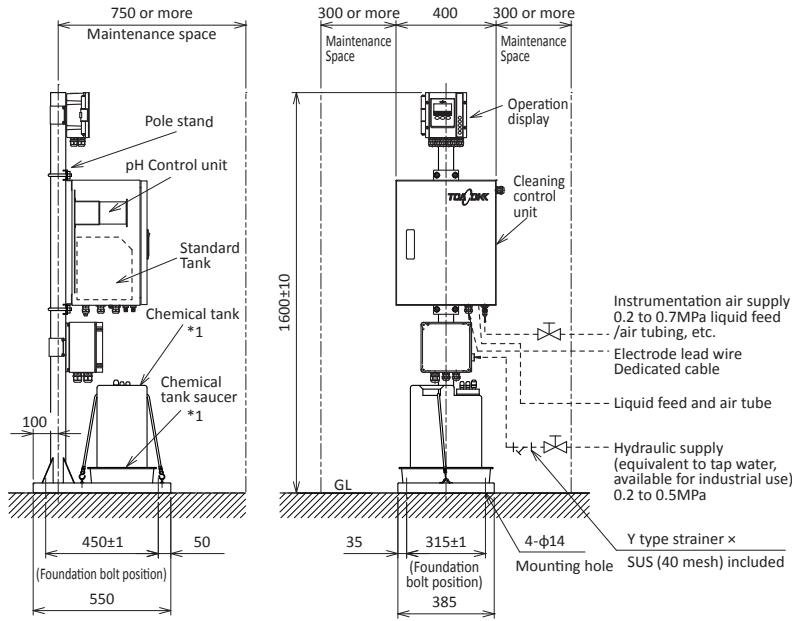

*1. Time of adoption of chemical cleaning option

Installation conditions

Install the product in a place that conforms to the following conditions.

1. The distance between the main body and the detector shall be within 5m maximum. (5m tube supplied as standard) (Install the main unit and detector as close as possible.)
2. The ambient temperature should be in the range of 0 to 50°C. (If the ambient temperature becomes 0°C or less, anti-freezing measures are required.)
3. No corrosive gas or vibrate.
4. Separate from motors and other electrical equipment that may cause inductive interference.
5. Maintenance space shall be available in the front/left/right direction of the main unit.
6. Space shall be available to allow removal of the upper electrode holder of the detector.
7. FL shall not be higher than GL by 2m or more.
8. Pipe the supplied Y-strainer to the washing water supply line.
9. If the wash feed water pressure exceeds 0.5MPa, install a pressure reduction valve so that it is less than or equal to 0.5MPa.
10. If there is a possibility of water hammering (water hammer) on the wash water supply line, installation of a water hammer preventer is recommended.
11. Condensation prevention measures are required in places exposed to direct sunlight.

● Detector

< Immersion-type Type A >

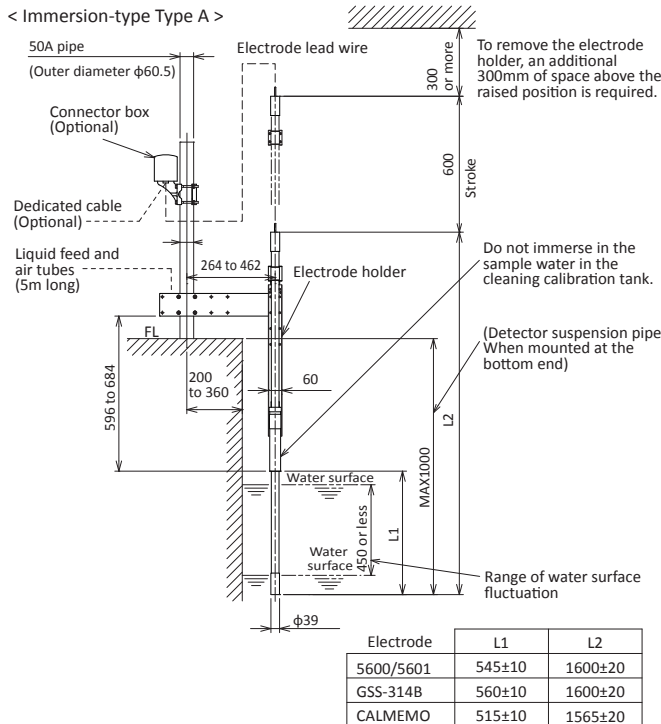

< Immersion-type Type B >

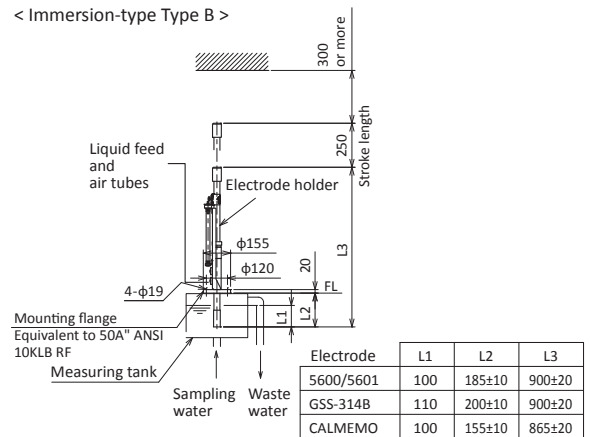

< Water Sampling Type >

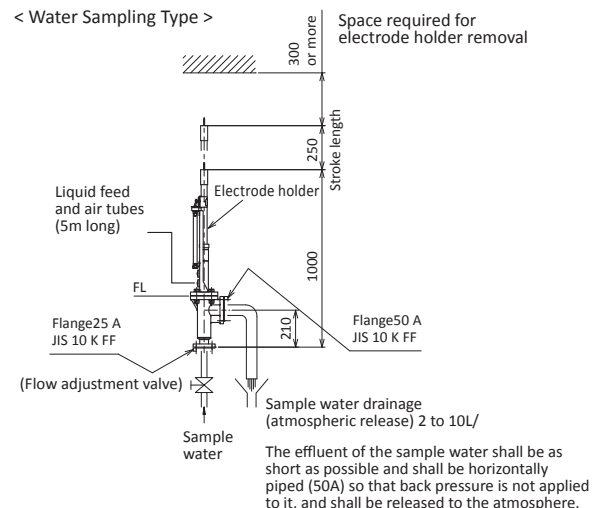

[Other options and special specifications]

Please inquire regarding requirements for special specifications such as detectors for deep vessels, heavy corrosion and salt-resistant coatings, wall or rack mounting, anti-freezing measures in the tubes of the liquid feed section to the detector, anti-condensation air purge measures in the liquid feed section, and compressed air supply (combine) units.

Related equipment

● Junction box

A junction box is required when the transmitter and electrode are installed away from each other and the standard electrode lead length is too short.

- Model : FC-4
- Construction : Outdoor installation
- Weight : Approx. 0.9kg
- Case material : ABS resin
- Base material : ABS resin
- Finish : Pearskin finish chromium plating
- Mounting : 25 - 50A pipe, wall or panel mount

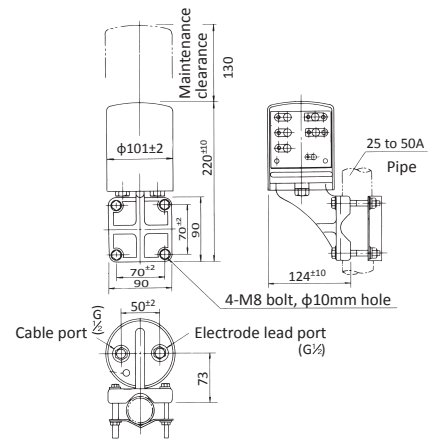

FC-4 dimensions

● Extension cable

The extension cable is a special cable specifically manufactured for a pH/ORP analyzer. It connects the controller and junction box.

- Model : EC-10
- Outside diameter : $\phi 8$
- Insulation : Polyethylene and PVC
- Sheath : PVC
- Insulation resistance between core conductors : $10^5 \text{M}\Omega$ or greater/100m.
- Maximum cable length : 100m, no cable splicing.
- Standard length : 5m - 100m (5m unit step)
- Weight : Approx. 0.5kg/5m

*The CALMEMO-pH electrode cannot be extended with a dedicated cable.

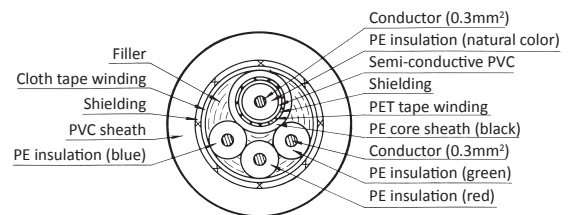

Cross section of EC-10



DKK-TOA CORPORATION

Overseas Sales Division:
DKK-TOA Corporation
29-10, 1-Chome, Takadanobaba, Shinjuku-ku,
Tokyo 169-8648 Japan
Tel : +81-3-3202-0225 Fax : +81-3-3202-5685
E-mail : intsales@dkktoa.com



CAUTION

Please read the operation manual carefully
before using products.

<http://www.toadkk.com/english>

Information and specifications are subject to change without notice.

Issued 10/2021